

SHARP

Important



R-7280G-BS

1000W

(IEC 60705)

MICROWAVE OVEN WITH GRILL

OPERATION MANUAL

ENGLISH

OPERATION MANUAL

This operation manual contains important information which you should read carefully before using your microwave oven.

IMPORTANT: There may be a serious risk to health if this operation manual is not followed or if the oven is modified so that it operates with the door open.



Attention: Your product is marked with this symbol. It means that used electrical and electronic products should not be mixed with general household waste. There is a separate collection system for these products.

A. Information on Disposal for Users (private households)

1. In the European Union

Attention: If you want to dispose of this equipment, please do not use the ordinary dust bin!

Used electrical and electronic equipment must be treated separately and in accordance with legislation that requires proper treatment, recovery and recycling of used electrical and electronic equipment.

Following the implementation by member states private households within the EU states may return their used electrical and electronic equipment to designated collection facilities free of charge*.

In some countries* your local retailer may also take back your old product free of charge if you purchase a similar new one.

*) Please contact your local authority for further details.

If your used electrical or electronic equipment has batteries or accumulators, please dispose of these separately beforehand according to local requirements.

By disposing of this product correctly you will help ensure that the waste undergoes the necessary treatment, recovery and recycling and thus prevent potential negative effects on the environment and human health which could otherwise arise due to inappropriate waste handling.

2. In other Countries outside the EU

If you wish to discard this product, please contact your local authorities and ask for the correct method of disposal.

For Switzerland: Used electrical or electronic equipment can be returned free of charge to the dealer, even if you don't purchase a new product. Further collection facilities are listed on the homepage of www.swico.ch or www.sens.ch.

B. Information on Disposal for Business Users.

1. In the European Union

If the product is used for business purposes and you want to discard it:

Please contact your SHARP dealer who will inform you about the take-back of the product. You might be charged for the costs arising from take-back and recycling. Small products (and small amounts) might be taken back by your local collection facilities.

For Spain: Please contact the established collection system or your local authority for take-back of your used products.

2. In other Countries outside the EU

If you wish to discard of this product, please contact your local authorities and ask for the correct method of disposal.



Operation manual

INFORMATION ON PROPER DISPOSAL 1

CONTENTS 2

SPECIFICATIONS 2

HOW YOUR OVEN WORKS 3

OVEN AND ACCESSORIES 4

CONTROL PANEL 5

IMPORTANT SAFETY INSTRUCTIONS 6-8

INSTALLATION 8

BEFORE OPERATION 9

SETTING THE CLOCK 9

MICROWAVE POWER LEVEL 9

MANUAL OPERATION 10

MICROWAVE COOKING 10-11

MICROWAVE SPEEDY COOKING 11

GRILL COOKING/MICRO+GRILL COOKING 12

OTHER CONVENIENT FUNCTIONS 13

REHEATING ADVICE 14

DEFROSTING ADVICE 15

DEFROSTING OPERATION 16

AUTO MENU OPERATION 17

AUTO MENU CHART 18

SUITABLE OVENWARE 19

CARE AND CLEANING 20

TROUBLESHOOTING 21

TO REPLACE THE MAINS PLUG 22

SPECIFICATIONS



ENGLISH

Model name:	R-7280G-BS
AC Line Voltage	: 220-230V, 50 Hz single phase
Distribution line fuse/circuit breaker	: 10 A
AC Power required: Microwave	: 1540 W
Output power: Microwave	: 1000 W
Grill	: 1000-1100 W
Off Mode (Energy Save Mode)	: less than 1.0 W
Microwave Frequency	: 2450 MHz*
Outside Dimensions (W) x (H) x (D)** mm	: 513.0 x 306.0 x 429.0
Cavity Dimensions (W) x (H) x (D)*** mm	: 330.0 x 228.0 x 370.0
Oven Capacity	: 28 litres***
Turntable	: ø 315 mm
Weight	: approx. 12.5 kg
Oven lamp	: 2 W/240 V

* This Product fulfils the requirement of the European standard EN55011. In conformity with this standard, this product is classified as group 2 class B equipment. Group 2 means that the equipment intentionally generates radio-frequency energy in the form of electromagnetic radiation for the heat treatment of food. Class B equipment means that the equipment is suitable to be used in domestic establishments.

** The depth does not include the door opening handle.

*** Internal capacity is calculated by measuring maximum width, depth and height. Actual capacity for holding food is less.

AS PART OF A POLICY OF CONTINUOUS IMPROVEMENT, WE RESERVE THE RIGHT TO ALTER DESIGN AND SPECIFICATIONS WITHOUT NOTICE.



HOW YOUR OVEN WORKS

Microwaves are energy waves, similar to those used for TV and radio signals.

Electrical energy is converted into microwave energy, which is directed into the oven cavity via a waveguide. To prevent food and grease entering the wave guide it is protected by the waveguide cover.

Microwaves cannot pass through metal, because of this the oven cavity is made of metal and there is a fine metal mesh on the door. During cooking the microwaves bounce off the sides of the oven cavity at random.

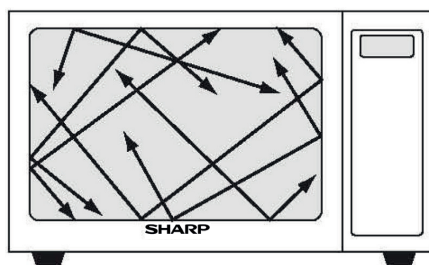

Microwaves will pass through certain materials, such as glass and plastic, to heat the food. (See 'Suitable Cookware' on page GB-19).

Water, sugar and fat in food absorb microwaves which cause them to vibrate. This creates heat by friction, in the same way your hands get warm when you rub them together.

The outer areas of the food are heated by the microwave energy, then the heat moves to the centre by conduction, as it does in conventional cooking. It is important to turn, rearrange or stir food to ensure even heating.

Once cooking is complete, the oven automatically stops producing microwaves.

Standing time is necessary after cooking, as it enables the heat to disperse equally throughout the food.



OVEN

1. Door
2. Door hinges
3. Oven lamp
4. Waveguide cover (DO NOT REMOVE)
5. Control panel
6. Coupling
7. Door latches
8. Oven cavity
9. Door seals and sealing surfaces
10. Door safety latches
11. Ventilation openings
12. Outer cabinet
13. Power supply cord
14. Door handle

ACCESSORIES:

Check to make sure the following accessories are provided:

- (15) Turntable (16) Turntable support (17) Coupling (18) Rack

- Place the turntable support in the centre of the oven floor so that it can freely rotate around the coupling. Then place the turntable on to the turntable support so that it locates firmly into the coupling.
 - To avoid turntable damage, ensure dishes and containers are lifted clear of the turntable rim when removing them from the oven.
- For use of the rack, refer to the grilling sections on page GB-12.

Never touch the grill when it is hot.

NOTE: When you order accessories, please mention two items: part name and model name to your dealer or SHARP authorised service centre.

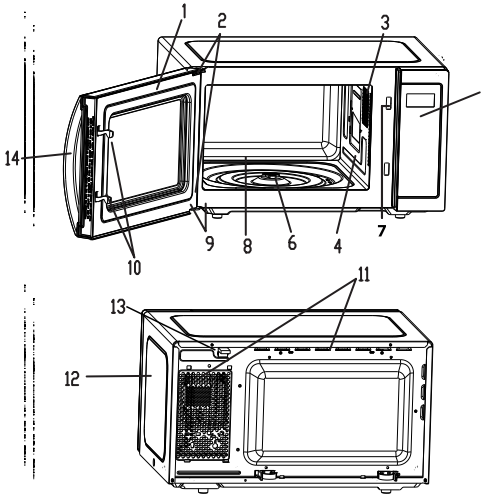

Hub (inside)

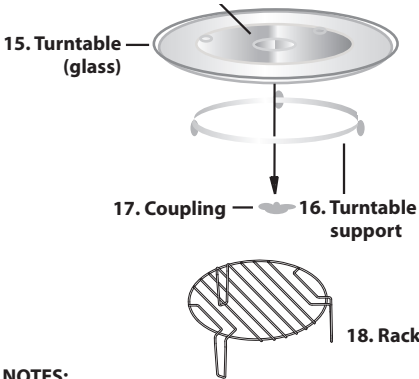

NOTES:

- The waveguide cover is fragile. Care should be taken when cleaning inside the oven to ensure that it is not damaged.
- After cooking fatty foods without a cover, always clean the cavity and especially the grill heating element thoroughly, these must be dry and free from grease. Built-up grease may overheat and begin to smoke or catch fire.
- Always operate the oven with the turntable and turntable support fitted correctly. This promotes thorough, even cooking. A badly fitted turntable may rattle, may not rotate properly and could cause damage to the oven.
- All food and containers of food are always placed on the turntable for cooking.
- The turntable rotates clockwise or anti-clockwise. The rotary direction may change each time you start the oven. This does not affect cooking performance.

⚠ WARNING: ⚠ This symbol means that the surfaces are liable to get hot during use. The door, outer cabinet, oven cavity, accessories and dishes will become very hot during operation. To prevent burns, always use thick oven gloves.



CONTROL PANEL

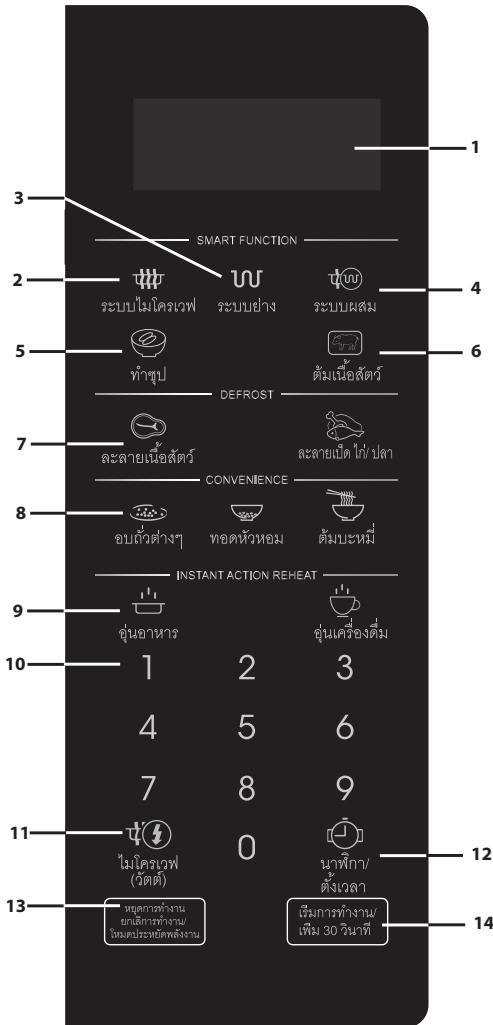

1. **DIGITAL DISPLAY**
2. **MICROWAVE key**
Press to select 1000W microwave power level.
3. **GRILL key**
4. **COMBI. key**
5. **BITTER MELON SOUP key**
6. **BOIL MEAT key**
7. **DEFROST MENU key**
 - Meat
 - Poultry/Fish
8. **CONVENIENCE MENU key**
 - อบตัวต่างๆ Roast Peanuts
 - พอดหัวหอม Fried Onion
 - ต้มบะหมี่ Instant Noodles
9. **INSTANT REHEATING key**
 - ช้อนอาหาร Dinner Plate
 - ช้อนเครื่องดื่ม Beverage
10. **NUMBER keys**
Press to select time/weight.
11. **MICROWAVE WATTAGE key**
12. **CLOCK/KITCHEN TIMER key**
Press to set clock or use as a minute timer.
13. **STOP/CLEAR/ECO key**
14. **START/ + 30 SECONDS key**



IMPORTANT SAFETY INSTRUCTIONS: READ CAREFULLY AND KEEP FOR FUTURE REFERENCE

To avoid the danger of fire.

The microwave oven should not be left unattended during operation. Power levels that are too high, or cooking times that are too long, may overheat foods resulting in a fire.

This oven is designed to be used on a countertop only. It is not designed to be built into a kitchen unit.

Do not place the oven in a cabinet.

The electrical outlet must be readily accessible so that the unit can be unplugged easily in an emergency.

The AC power supply must be 220-230 V, 50 Hz, with a minimum 10 A distribution line fuse, or a minimum 10 A distribution circuit breaker.

A separate circuit serving only this appliance should be provided.

Do not place the oven in areas where heat is generated. For example, close to a conventional oven.

Do not install the oven in an area of high humidity or where moisture may collect.

Do not store or use the oven outdoors.

If smoke is observed, switch off or unplug the oven and keep the door closed in order to stifle any flames.

Use only microwave-safe containers and utensils. See page GB-19. Utensils should be checked to ensure that they are suitable for use in microwave ovens.

When heating food in plastic or paper containers, keep an eye on the oven due to the possibility of ignition.

Clean the waveguide cover, the oven cavity, the turntable and turntable support after use. These must be dry and free from grease. Built-up grease may overheat and begin to smoke or catch fire.

Do not place flammable materials near the oven or ventilation openings.

Do not block the ventilation openings.

Remove all metallic seals, wire twists, etc., from food and food packages. Arcing on metallic surfaces may cause a fire.

Do not use the microwave oven to heat oil for deep frying. The temperature cannot be controlled and the oil may catch fire.

To make popcorn, use only special microwave popcorn makers.

Do not store food or any other items inside the oven.

Check the settings after you start the oven to ensure the oven is operating as desired.

To avoid overheating and fire, special care must be taken when cooking or reheating foods with a high sugar or fat content, for example, Sausage rolls, Pies or Christmas pudding.

See the corresponding hints in the operation manual.

To avoid the possibility of injury

WARNING:

Do not operate the oven if it is damaged or malfunctioning. Check the following before use:

- The door; make sure the door closes properly and ensure it is not misaligned or warped.
- The hinges and safety door latches; check to make sure they are not broken or loose.
- The door seals and sealing surfaces; ensure that they have not been damaged.
- Inside the oven cavity or on the door; make sure there are no dents.
- The power supply cord and plug; ensure that they are not damaged.

If the door or door seals are damaged, the oven must not be operated until it has been repaired by a competent person.

Never adjust, repair or modify the oven yourself. It is hazardous for anyone other than a competent person to carry out any service or repair operation which involves the removal of a cover which gives protection against exposure to microwave energy.

Do not operate the oven with the door open or alter the door safety latches in any way. Do not operate the oven if there is an object between the door seals and sealing surfaces.

Do not allow grease or dirt to build up on the door seals and adjacent parts. Clean the oven at regular intervals and remove any food deposits. Follow the instructions for "Care and Cleaning" on page GB-20. Failure to maintain the oven in a clean condition could lead to a deterioration of the surface that could adversely affect the life of the appliance and possibly result in a hazardous situation.

Individuals with PACEMAKERS should check with their doctor or the manufacturer of the pacemaker for precautions regarding microwave ovens.

To avoid the possibility of electric shock

Under no circumstances should you remove the outer cabinet.

Never spill or insert any objects into the door lock openings or ventilation openings. In the event of a spill, turn off and unplug the oven immediately, and call an authorised SHARP service agent.

Do not immerse the power supply cord or plug in water or any other liquid.

Do not let the power supply cord hang over the edge of a table or work surface.

Keep the power supply cord away from heated surfaces, including the rear of the oven.

Keep the appliance and its cord out of reach of children less than 8 years.



IMPORTANT SAFETY INSTRUCTIONS

Do not attempt to replace the oven lamp yourself or allow anyone who is not an electrician authorised by SHARP to do so. If the oven lamp fails, please consult your dealer or an authorised SHARP service agent.

If the power supply cord of this appliance is damaged, it must be replaced with a special cord.

The exchange must be made by an authorised SHARP service agent.

To avoid the possibility of explosion and sudden boiling:

WARNING: Liquids and other foods must not be heated in sealed containers since they are liable to explode.

Microwave heating of beverages can result in delayed eruptive boiling, therefore care must be taken when handling the container.

Never use sealed containers. Remove seals and lids before use. Sealed containers can explode due to a build up of pressure even after the oven has been turned off.

Take care when microwaving liquids. Use a wide mouthed container to allow bubbles to escape.

Never heat liquids in narrow necked containers such as baby bottles, as this may result in the contents erupting from the container when heated and cause burns.

To prevent sudden eruption of boiling liquid and possible scalding:

1. Do not use excessive amount of time.
2. Stir liquid prior to heating/reheating.
3. It is advisable to insert a glass rod or similar utensil (not metal) into the liquid whilst reheating.
4. Let liquid stand for at least 20 seconds in the oven at the end of cooking time to prevent delayed eruptive boiling.

Do not cook eggs in their shells, and whole hard boiled eggs should not be heated in microwave ovens since they may explode even after microwave cooking has ended. To cook or reheat eggs which have not been scrambled or mixed, pierce the yolks and the whites, or the eggs may explode. Shell and slice hard boiled eggs before reheating them in the microwave oven.

Pierce the skin of such foods as potatoes, sausages and fruit before cooking, or they may explode.

To avoid the possibility of burns

WARNING: The contents of feeding bottles and baby food jars must be stirred or shaken and the temperature checked before consumption, in order to avoid burns.

Use pot holders or oven gloves when removing food from the oven to prevent burns.

Always open containers, popcorn makers, oven cooking bags, etc., away from the face and hands to avoid steam burns and eruption of boiling.

To avoid burns, always test food temperature and stir before serving and pay special attention to the temperature of food and drink given to babies, children or the elderly. Accessible parts may become

hot during use. Young children should be kept away. Temperature of the container is not a true indication of the temperature of the food or drink; always check the food temperature.

Always stand back from the oven door when opening it to avoid burns from escaping steam and heat.

Slice stuffed baked foods after heating to release steam and avoid burns.

Keep children away from the door to prevent them burning themselves.

To avoid misuse by children

WARNING: Only allow children aged from 8 years and above to use the oven without supervision when adequate instructions have been given so that the child is able to use the oven in a safe way and understands the hazards of improper use. When the appliance is operated in the GRILL, MIX GRILL and AUTO MENU operation, children should only use the oven under adult supervision due to the temperature generated. This appliance is not intended for use by persons (including children) with reduced physical, sensory or mental capabilities, or lack of experience and knowledge, unless they have been given supervision or instruction concerning use of the appliance by a person responsible for their safety. Children should be supervised to ensure that they do not play with the appliance.

To prevent the oven from losing its balance, do not lean or swing on the oven door or the handle. Do not play with the oven or use it as a toy. Children should be taught all important safety instructions: use of pot holders, careful removal of food coverings; paying special attention to packaging (e.g. self-heating materials) designed to make food crisp, as they may be extra hot.

Other warnings

Never modify the oven in any way.

Do not move the oven while it is in operation.

This appliance is intended to be used in household and similar applications such as:

- staff kitchen areas in shops, offices and other working environments;
- farm houses;
- by clients in hotels, motels and other residential environments;
- bed and breakfast type environments.

This oven is for home food preparation only and may only be used for cooking food. It is not suitable for commercial or laboratory use.

To promote trouble-free use of your oven and avoid damage.

Never operate the oven when it is empty. When using a browning dish or self-heating material, always place a heat-resistant insulator such as a porcelain plate under it to prevent damage to the turntable and turntable support due to heat stress. The preheating time specified in the dishes instructions must not be exceeded.

IMPORTANT SAFETY INSTRUCTIONS



Do not use metal utensils, which reflect microwaves and may cause electrical arcing. Do not put cans in the oven.

Use only the turntable and the turntable support designed for this oven. Do not operate the oven without the turntable.

To prevent the turntable from breaking:

- Before cleaning the turntable with water, leave the turntable to cool.
- Do not put hot foods or hot utensils on a cold turntable.
- Do not put cold foods or cold utensils on a hot turntable.

Do not place anything on the outer cabinet during operation.

NOTE:

Do not use plastic containers for microwaving if the oven is still hot from using the GRILL and MIX GRILL operation because they may melt.

Plastic containers must not be used during above modes unless the container manufacturer says they are suitable.

If you are unsure how to connect your oven, please consult an authorised, qualified electrician.

Neither the manufacturer nor the dealer can accept any liability for damage to the oven or personal injury resulting from failure to observe the correct electrical connection procedure.

Water vapour or drops may occasionally form on the oven walls or around the door seals and sealing surfaces. This is a normal occurrence and is not an indication of microwave leakage or a malfunction.



This symbol means that the surfaces are liable to get hot during use.

INSTALLATION



- Remove all packing materials from the inside of the oven cavity and remove any protective film found on the microwave oven cabinet surface. Check the oven carefully for any signs of damage.
- Place the oven on a secure, level surface, strong enough to take the oven weight, plus the heaviest item likely to be cooked in the oven. Do not place the oven in a cabinet.
- Select a level surface that provides enough open space for the intake and/or outlet vents. The rear surface of appliance shall be placed against a wall.
 - The minimum installation height is 85 cm.
 - A minimum space of 20 cm is required between the oven and any adjacent walls.
 - Leave a minimum space of 30 cm above the oven.
 - Do not remove the feet from the bottom of the oven.
 - Blocking the intake and/or outlet openings can damage the oven.
 - Place the oven as far away from radios and TV as possible. Operation of microwave oven may cause interference to your radio or TV reception.

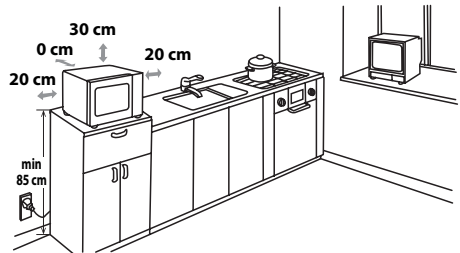

- The oven door may become hot during cooking. Place the oven so that the bottom of the oven is 85 cm or more above the floor. Keep children away from the door to prevent them from burning themselves.
- Securely connect the plug of the oven to a standard earthed (grounded) household electrical outlet.

WARNING: Do not place the oven where heat, moisture or high humidity are generated, (for example, near or above a conventional oven) or near combustible materials (for example, curtains).

Do not block or obstruct air vent openings.
Do not place objects on top of the oven.



BEFORE OPERATION



Plug in the oven. The oven display will display: "0:00", an audible signal will sound once.

This model has a clock function and the oven uses less than 1.0 W in stand by mode. **To set the clock, see below.**



SETTING THE CLOCK

Your oven has a 12 hour clock mode.

1. Press the **CLOCK/SET TIMER** key  once and "00:00" will flash.
2. Press the number keys and enter the current time.
3. Press the **CLOCK/SET TIMER** key  to finish clock setting.

NOTES:

- If the clock is set, when cooking is complete, the display will show the correct time of day. If the clock has not been set, the display will only show "0:00" when cooking is complete.
- To check the time of day during a cooking process, press **CLOCK/SET TIMER** key and the LED will display the time of day for 2-3 seconds. This does not affect the cooking process.
- In the process of clock setting, if the **STOP/CLEAR** key is pressed or if there is no operation within 1 minute, the oven will go back to the former setting.
- If the electrical power supply to your microwave oven is interrupted, the display will intermittently show "0:00" after the power is reinstated. If this occurs during cooking, the programme will be erased. The time of day will also be erased.



MICROWAVE POWER LEVEL

Power Level	Press the MICROWAVE WATTAGE key 	Display (Wattage)
HIGH	x1	1000W
	x2	900W
MEDIUM HIGH	x3	800W
	x4	700W
MEDIUM	x5	600W
	x6	500W
MEDIUM LOW (DEFROST)	x7	400W
	x8	300W
LOW	x9	200W
	x10	100W
	x11	0W

- Your oven has 11 power levels, as shown.
- To change the power level for cooking, press the **MICROWAVE WATTAGE** key until the display indicates the desired level. Press the **START** key to start the oven.
- To check the power level during cooking, press the **MICROWAVE** key. As long as your finger is pressing the **MICROWAVE** key the power level will be displayed. The oven continues to count down although the display will show the power level.
- If "0W" is selected, the oven will work with the fan but no power. You can use this level to remove odour.

Generally the following recommendations apply:

1000W/ 900W -(HIGH) used for fast cooking or reheating e.g. for casseroles, hot beverages, vegetables etc.

800W/ 700W -(MEDIUM HIGH) used for longer cooking of dense foods such as roast joints, meat loaf and plated meals, also for sensitive dishes such as sponge cakes. At this reduced setting, the food will cook evenly without over cooking at the sides.

600W/ 500W -(MEDIUM) for dense foods which require a long cooking time when cooked conventionally, e.g. beef casserole,

it is advisable to use this power setting to ensure the meat will be tender.

400W/ 300W -(MEDIUM LOW) to defrost, select this power setting, to ensure that the dish defrosts evenly. This setting is also ideal for simmering rice, pasta, dumplings and cooking egg custard.

200W/ 100W -(LOW) For gentle defrosting, e.g. cream gateaux or pastry.

MANUAL OPERATION



Opening the door:

To open the oven door, pull the door opening handle.

Starting the oven:

Prepare and place food in a suitable container onto the turntable or place directly onto the turntable. Close the door and press the **START/+30 SEC.** key after selecting the desired cooking mode.

Once the cooking programme has been set and the **START/+30 SEC.** key is not pressed in 1 minute, the setting will be cancelled.

The **START/+30 SEC.** key must be pressed to continue cooking if the door is opened during cooking. The audible signal sounds once by efficient press, inefficient press will be no response.

Use the **STOP/CLEAR** key to:

1. Erase a mistake during programming.
2. Stop the oven temporarily during cooking.
3. Cancel a programme during cooking, press the **STOP/CLEAR** key twice.
4. To set and to cancel the child lock (refer to page GB-13).

เริ่มการทำงาน
เพิ่ม 30 วินาที

หยุดการทำงาน
ยกเลิกการทำงาน
ใหม่และรีเซ็ตพลังงาน

MICROWAVE COOKING



Your oven can be programmed for up 99 minutes 99 seconds (99.99).

MANUAL COOKING/ MANUAL DEFROSTING

- Use microwave power levels 1000W to 100W and enter the cooking time to cook or defrost (refer to page GB-9).
- Stir or turn the food, where possible, 2 - 3 times during cooking.
- After cooking, cover the food and leave to stand, where recommended.
- After defrosting, cover the food in foil and leave to stand until thoroughly defrosted.

Example:

To cook 10 minutes on 1000W microwave power.

1. Input the power level by pressing the **MICROWAVE** key once for 1000W.
2. Enter the cooking time by pressing the number keys.
3. Press the **START/+30 SEC.** key to start cooking. (The display will count down through the set cooking/defrosting time.)



10:00

เริ่มการทำงาน
เพิ่ม 30 วินาที

10:00

NOTE:

- When the oven starts, the oven lamp will light and the turntable will rotate clockwise or anticlockwise.
- If the door is opened during cooking/defrosting to stir or to turn over food, the cooking time on the display stops automatically. The cooking/ defrosting time starts to count down again when the door is closed and the **START** key is pressed.
- When cooking/defrosting is complete, open the door or press **STOP/CLEAR** key and the time of day will re-appear on the display, if the clock has been set.
- If you wish to know the power level during cooking, press the **MICROWAVE** key. As long as your finger is touching the **MICROWAVE** key, the power level will be displayed.

IMPORTANT:

- Close the door after cooking / defrosting. Please note that the light will remain on when the door is open, this is for safety reasons to remind you to close the door.
- If you cook food for more than the standard time (see chart below) using the same cooking mode, the oven's safety mechanisms will automatically activate. The microwave power level will be reduced or the grill heating element will turn on and off.

Cooking Mode	Standard time
Microwave 1000W	99 minutes 99seconds
Grill cooking	Intermittent operation, temperature.
Mix grill cooking	99 mins 99 sec



MICROWAVE COOKING

Example:

To cook 10 minutes on 700W microwave power.

1. Input the power level by pressing the **MICROWAVE WATTAGE** key several times for 700W.



2. Press the **START/+30 SEC.** key to confirm the power.



3. Enter the cooking time by pressing the number keys.

10:00

4. Press the **START/+30 SECONDS** key to start cooking.
(The display will count down through the set cooking/defrosting time.)



10:00



MICROWAVE SPEEDY COOKING

You can directly start cooking on 1000W microwave power level for the cooking time you desired.
Maximum cooking time is 99 minutes and 99 seconds.

a. Example:

To cook 10 minutes on 1000W microwave power.

1. Enter the cooking time by pressing the number keys.

10:00

2. Press the **START/+30 SEC.** key to start cooking.
(The display will count down.)



10:00

b. Direct start

You can directly start cooking on 1000W microwave power level for 30 seconds by pressing the **START/+30 SEC.** key.

c. Extend the cooking time

You can extend the cooking time during manual cooking, time defrost and auto menu operation in multiples of 30 seconds if the **START/+30 S** key is pressed while the oven is in operation. During the weight defrost, the cooking time cannot be increased by pressing **START/+30S** key.

GRILL COOKING/MICRO+GRILL COOKING



1. GRILL ONLY COOKING

The grill at the top of the oven cavity has one power setting only. The grill is assisted by the turntable which rotates simultaneously to ensure even browning. Use the rack for grilling small items of food such as bacon, gammon and teacakes. Food can be placed either directly onto the rack, or into a flan dish/heat-resistant plate on the rack.

Example:

To grill for 20 minutes, using **GRILL** key.

1. Press **GRILL** key once.



2. Enter the required heating time by pressing the number keys.



3. Press the **START/+30 SEC.** key to start the grilling.

(The display will count down through the set grilling time.)



Note:

Halfway through the grilling time an audible signal will sound twice this will remind you to turn the food over to ensure even browning. Please be aware that the oven will not stop automatically during grilling.

Turnover the food halfway through, close the door and then press the **START/+30sec.** button to continue grilling.

2. MICRO+GRILL COOKING

MICRO+GRILL combines microwave power with the grill. **MICRO+GRILL** means to cook by Microwave power and Grill power alternately.

The combination of microwave power with the grill reduces cooking time and provides a crisp, brown finish. There are 2 choices for the combination:

COMBINATION 1 (Display: C-1)

55% time for microwave power, 45% time for grill cooking. Use for fish and au gratin.

COMBINATION 2 (Display: C-2)

36% time for microwave cooking, 64% time for grill cooking. Use for pudding omelettes and poultry.

Example:

To cook for 15 minutes, using **COMBI.** with 55% time microwave power and 45% grill power (C-1).

1. Press **COMBI.** key once.



2. Press the **START/+30 SEC.** key to confirm the power.



4. Press the **START/+30 SEC.**

key to start the cooking.

(The display will count down through the set cooking time.)



NOTES for GRILL and MICRO+GRILL COOKING:

- It is not necessary to preheat the grill.
- When browning foods in a deep container, place on the turntable.
- You may detect smoke or a burning smell when using the grill for the first time. This is normal and not a sign that the oven is out of order. To avoid this problem, when first using the oven, heat the oven without food for 20 minutes on grill.

IMPORTANT: During operation, to allow smoke or smells to disperse open a window or switch the kitchen ventilation on.

⚠ WARNING:

The door, outer cabinet, oven cavity and accessories will become very hot during operation. To prevent burns, always use thick oven gloves.



OTHER CONVENIENT FUNCTIONS

1. KITCHEN TIMER FUNCTION :

You can use the kitchen timer for timing where microwave cooking is not involved for example to time boiled eggs cooked on conventional hob or to monitor the standing time for cooked/defrosted food.

Example:

To set the timer for 5 minutes.

1. Press the **CLOCK/ SET TIMER** key twice.
2. Enter the desired time by pressing the number keys.
3. Press the **START/ +30 SEC.** key to start the timer.



When the timer time arrives, the audible signal will sound 5 times and the LED will display End. You can enter any time up to 99 minutes, 99 seconds. To cancel the KITCHEN TIMER whilst counting down, simply press the **STOP/CLEAR** key.

NOTE: The KITCHEN TIMER function cannot be used whilst cooking.

2. SEQUENCE COOKING

This function quickly defrosts food while enabling you to choose a suitable defrost period, depending on the food type. Follow the example below for details on how to operate this function. The time range is 0:05-99:99. This function allows you to cook using up to 2 different stages.

Once programmed there is no need to interfere with the cooking operation as the oven will automatically move onto the next stage. An audible signal will sound once after the first stage. If one chosen stage is defrosting, this should be the first stage of sequence cooking.

Note: AUTO MENU cannot be set as one of the multiple sequences.

Example: If you want to cook the food with grill for 5 minutes, then to cook with 800W microwave power for 7 minutes. The steps are as follows:

- 1. Press the **GRILL** button once, in the LED display Gr will appear.
- 2. Enter the grilling time by pressing the **NUMBER** keys and the display shows "5:00" minutes.
- 3. Press the **MICROWAVE WATTAGE** button once.
- 4. Input the power level by pressing the **MICROWAVE WATTAGE** button three times for 800W.
- 5. Press the **START/+30sec.** button to confirm.
- 6. Enter the cooking time by pressing the **NUMBER** keys and the display shows "7:00" minutes.
- 7. Press the **START/+30sec.** button to start cooking.

3. CHILD LOCK:

Use to prevent unsupervised operation of the oven by children.

a. To set the CHILD LOCK:

Press and hold the **STOP/CLEAR** key for 3 seconds until a long a beep sounds. The display will show 0:00 or current time if clock has been set.

b. To cancel the CHILD LOCK:

Press and hold the **STOP/CLEAR** key for 3 seconds until a long beep sounds.

4. ECO FUNCTION:

a. In waiting state, press **STOP/CLEAR/ECO** key once briefly, LED will display off. When LED will display off, press any button to turn back to waiting state.

b. In waiting state, if no operation in 10 minutes, the oven will sound once and LED will be off.

c. During child lock state, ECO functio will not work.



For the reheating of foods, follow the advice and guidelines below to ensure food is thoroughly reheated before serving.

Plated meals	<p>Remove any poultry or meat portions, reheat these separately, see below.</p> <p>Place smaller items of food to the centre of the plate, larger and thicker foods to the edge. Cover with vented microwave cling film and reheat on 50%, stir/rearrange halfway through reheating.</p> <p>NOTE: Ensure the food is thoroughly reheated before serving.</p>	
Sliced meat	<p>Cover with vented microwave cling film and reheat on 50%. Rearrange at least once to ensure even reheating.</p> <p>NOTE: Ensure the meat is thoroughly reheated before serving.</p>	
Poultry portions	<p>Place thickest parts of the portions to the outside of the dish, cover with vented microwave cling film and reheat on 70%. Turn over halfway through reheating.</p> <p>NOTE: Ensure the poultry is thoroughly reheated before serving.</p>	
Casseroles	<p>Cover with vented microwave cling film or a suitable lid and reheat on 50%. Stir frequently to ensure even reheating.</p> <p>NOTE: Ensure the food is thoroughly reheated before serving.</p>	

To achieve the best results when reheating, select a suitable microwave power level appropriate to the type of food. e.g. A bowl of vegetables can be reheated using 100%, while a lasagne which contains ingredients that cannot be stirred, should be reheated using 50%.

NOTES:

- Remove food from foil or metal containers before reheating.
- Reheating times will be affected by the shape, depth, quantity and temperature of food together with the size, shape and material of the container.

⚠ WARNING:
Never heat liquids in narrow-necked containers, as this could result in the contents erupting from the container and may cause burns.

- To avoid overheating and fire, special care must be taken when reheating foods with a high sugar or fat content, e.g. mince pies or Christmas pudding.
- Never heat oil or fat for deep frying as this may lead to overheating and fire.
- Canned potatoes should not be heated in the microwave oven, follow the manufacturer's instructions on the can.

⚠ WARNING:
The contents of feeding bottles and baby food jars are to be stirred or shaken and the temperature is to be checked before consumption to avoid burns.



DEFROSTING ADVICE

Defrosting food using your microwave oven is the quickest method of all.

It is a simple process but the following instructions are essential to ensure the food is thoroughly defrosted.

Rearrange	Foods that are placed towards the outside of the dish will defrost quicker than foods in the centre. It is therefore essential that the food is rearranged up to 4 times during defrosting. Move closely packed pieces from the outside to the centre and rearrange over-lapping areas. This will ensure that all parts of the food defrosts evenly.
Separate	Foods may be stuck together when removed from the freezer. It is important to separate foods as soon as it is possible during defrosting, e.g. bacon rashers, chicken fillets.
Shield	Some areas of food being defrosted may become warm. To prevent them becoming warmer and starting to cook, these areas can be shielded with small pieces of foil, which reflect microwaves, e.g. legs and wings on a chicken.
Stand	Standing time is necessary to ensure food is thoroughly defrosted. Defrosting is not complete once the food is removed from the microwave oven. Food must stand, covered, for a length of time to ensure the centre has completely defrosted.
Turn over	It is essential that all foods are turned over at least 3 - 4 times during defrosting. This is important to ensure thorough defrosting.

NOTES:

- Remove all packaging and wrapping before defrosting.
- To defrost food, use microwave power levels 30% or 10%.

DEFROST OPERATION



The microwave oven is pre-programmed with a time and power level so that the following food is defrosted easily: pork, chicken and fish. The weight range for this food is from 0.1kg – 1.5kg. Follow the example below for details on how to operate these functions.

1. MEAT DEFROST

Example: To defrost the steak for 500g.

1. Select the menu required by pressing the **MEAT** key twice.



the display will show:

2. Enter the defrosting time by pressing the number keys.

3. Press the **START/+30 SEC.** key to start defrosting.

2. POULTRY/FISH DEFROST

Example: To defrost the fish for 500g.

1. Select the menu required by pressing the **POULTRY/FISH** key three times.



the display will show:

2. Enter the defrosting time by pressing the number keys.

3. Press the **START/+30 SEC.** key to start defrosting.

Frozen foods are defrosted from -18°C.

NOTES FOR WEIGHT DEFROST:

- Before freezing foods, ensure food is fresh and of good quality.
- Food weight should be rounded up to the nearest 0.1kg, for example, 0.65kg to 0.7kg.
- If necessary, shield small areas of meat or poultry with flat pieces of aluminium foil. This will prevent areas from becoming warm during defrosting. Ensure the foil does not touch the oven walls.

DEFROST CHART

Code	Menu	Weight(g)
d1-1	Mince	100-1500
d1-2	Steak/Chops	500-1500
d1-3	Pork	500-1500
d2-1	Whole Chicken	800-1500
d2-2	Chicken Fillet	500-1000
d2-3	Fish Fillet	500-1000



AUTO MENU OPERATION

The **AUTO MENU** keys automatically work out the correct cooking mode and cooking of the foods. Follow the example below for details on how to operate this function.

1. BITTER MELON SOUP

Example: To cook bitter melon soup (400g) by using the AUTO MENU function.

1. Select the required menu by pressing the **Bitter Melon Soup** key once.
2. Press the **START/+30 SEC.** key to start cooking. (The display will count down through cooking time)



the display will show:

NOTES:

- The weight of the food is pre-programmed.

2. ROAST PEANUTS

Example: To cook roast peanuts (100g) by using the AUTO MENU function.

1. Select the required menu by pressing the **Roast Peanuts** key once.
2. Press the **START/+30 SEC.** key to start cooking. (The display will count down through cooking time)



the display will show:

NOTES:

- The weight of the food is pre-programmed.

3. DINNER PLATE

Example: To reheat the food (350g) by using the AUTO MENU function.

1. Select the required menu by pressing the **Dinner Plate** key twice.
2. Press the **START/+30 SEC.** key to start cooking. (The display will count down through cooking time)



the display will show:

NOTES:

- You can choose 250g/350g/500g.

AUTO MENU CHART



Menu	Weight(g)	Power
Bitter Melon Soup	400	P100+P50
Boil meat	500	P100
Roast peanuts	100	C-1 Note: Turn over the food when 2 minutes left.
Fried onion	100g (80g onion+20g oil)	P100/P50 Note: No need to turn over the food.
Instant noodles	80g noodle+400g boiling water	P100
Dinner plate	250	P100
	350	
	500	
Beverage	200	P100
	400	
	600	



SUITABLE OVENWARE

To cook/defrost food in a microwave oven, the microwave energy must be able to pass through the container to penetrate the food. Therefore it is important to choose suitable cookware.

Round/oval dishes are preferable to square/oblong ones, as the food in the corners tends to overcook. A variety of cookware can be used as listed below.

Cookware	Microwave Safe	Grill	Comments
Aluminium foil Foil Containers	✓ / ✗	✓	Small pieces of aluminium foil can be used to shield food from overheating. Keep foil at least 2cm from the oven walls, as arcing may occur. Foil containers are not recommended unless specified by the manufacturer, e.g. Microfoil [®] , follow instructions carefully.
Browning dishes	✓	✗	Always follow the manufacturers instructions. Do not exceed heating times given. Be very careful as these dishes become very hot.
China and ceramics	✓ / ✗	✗	Porcelain, pottery, glazed earthenware and bone china are usually suitable, except for those with metallic decoration.
Glassware e.g. Pyrex [®]	✓	✓	Care should be taken if using fine glassware as it can break or crack if heated suddenly.
Metal	✗	✓	It is not recommended to use metal cookware as it will arc, which can lead to fire.
Plastic/Polystyrene e.g fast food containers	✓	✗	Care must be taken as some containers warp, melt or discolour at high temperatures.
Cling film	✓	✗	It should not touch the food and must be pierced to let the steam escape.
Freezer/Roasting bags	✓	✗	Must be pierced to let steam escape. Ensure bags are suitable for microwave use.
Paper - Plates, cups and kitchen paper	✓	✗	Do not use plastic or metal ties, as they may melt or catch fire due to the metal 'arcing'.
Straw and wooden Containers	✓	✗	Only use for warming or to absorb moisture. Care must be taken as overheating may cause fire.
Recycled paper and newspaper	✗	✓	Always attend the oven when using these materials as overheating may cause fire. May contain extracts of metal which will cause 'arcing' and may lead to fire.

⚠ WARNING:

When heating food in plastic or paper containers, monitor the oven due to the possibility of ignition.



CAUTION: DO NOT USE COMMERCIAL OVEN CLEANERS, STEAM CLEANERS, ABRASIVE, HARSH CLEANERS, ANY THAT CONTAIN SODIUM HYDROXIDE OR SCOURING PADS ON ANY PART OF YOUR MICROWAVE OVEN.

Before cleaning, make sure the oven cavity, door, oven cabinet and accessories are completely cool. CLEAN THE OVEN AT REGULAR INTERVALS AND REMOVE ANY FOOD DEPOSITS - Keep the oven clean, or the oven could lead to a deterioration of the surface. This could adversely affect the life of the appliance and possibly result in a hazardous situation.

Oven exterior

The outside of your oven can be cleaned easily with mild soap and water. Make sure the soap is wiped off with a moist cloth, and dry the exterior with a soft towel.

Control panel

Open the door before cleaning to de-activate the control panel. Care should be taken in cleaning the control panel. Using a cloth dampened with water only, gently wipe the panel until it becomes clean.

Avoid using excessive amounts of water. Do not use any sort of chemical or abrasive cleaner.

Oven Interior

1. For cleaning, wipe any splatters or spills with a soft damp cloth or sponge after each use while the oven is still warm. For heavier spills, use a mild soap and wipe several times with a damp cloth until all residues

are removed. Built-up splashes may overheat and begin to smoke or catch fire, and cause arcing. Do not remove the waveguide cover.

2. Make sure that mild soap or water does not penetrate the small vents in the walls which may cause damage to the oven.

3. Do not use spray type cleaners on the oven interior.

4. Heat up your oven regularly by using the grill and heat the oven without food for 20 minutes on grill (page GB-12). Remaining food or fat splashed can cause smoke or bad smell.

Keep the waveguide cover clean at all times.

The waveguide cover is constructed from a fragile material and should be cleaned with care (follow the cleaning instructions above).

NOTE: Excessive soaking may cause disintegration of the waveguide cover.

The waveguide cover is a consumable part and without regular cleaning, will need to be replaced.

Accessories

The accessories like turntable, turntable support and rack should be washed in a mild washing up liquid solution and dried. They are dishwasher safe.

Door

To remove all trace of dirt, regularly clean both sides of the door, the door seals and adjacent parts with a soft, damp cloth. Do not use abrasive cleaner.

NOTE: A steam cleaner should not be used.

Cleaning tip - For easier cleaning of your oven:

Place half a lemon in a bowl, add 300ml (1/2 pint) water and heat on 100% for 10 -12 minutes.

Wipe the oven clean using a soft, dry cloth.



TROUBLESHOOTING

Keep the power supply cord away from heated surface. If you think the oven is not working properly there are some simple checks you can carry out yourself before calling an engineer. This will help prevent unnecessary service calls if the fault is something simple.

Follow this simple check below: Place half a cup of water on the turntable and close the door. Programme the oven to cook for 1 minute using 100% microwave power.

1. Does the oven lamp come on when it is cooking?
2. Does the turntable rotate?
3. Does the cooling fan work? (Check by placing your hand above the air vent openings.)
4. After 1 minute does the audible signal sound?
5. Is the water in the cup hot?
6. After 3 minutes, does the grill heating element become red?

If you answer "NO" to any question first check that the oven is plugged in properly and the fuse has not blown. If there is no fault with either, check against the troubleshooting chart below.

WARNING: Never adjust, repair or modify the oven yourself. It is hazardous for anyone other than a SHARP trained engineer to carry out servicing or repairs. This is important as it may involve the removal of covers that provide protection against microwave energy.

- The door seal stops microwave leakage during oven operation, but does not form an airtight seal. It is normal to see drops of water, light or feel warm air around the oven door. Food with a high moisture content will release steam and cause condensation inside the door which may drip from the oven.
- **Repairs and Modifications:** Do not attempt to operate the oven if it is not working properly.
- **Outer Cabinet & Lamp Access:** Never remove the outer cabinet. This is very dangerous due to high voltage parts inside which must never be touched, as this could be fatal.
Your oven is not fitted with a lamp access cover. If the lamp fails, do not attempt to replace the lamp yourself, call a SHARP approved service facility.

TROUBLESHOOTING CHART

QUERY	ANSWER
Draught circulates around the door.	When the oven is working, air circulates within the cavity. The door does not form an airtight seal so air may escape from the door.
Condensation forms in the oven, and may drip from the door.	The oven cavity will normally be colder than the food being cooked, and so steam produced when cooking will condense on the colder surface. The amount of steam produced depends on the water content of the food being cooked. Some foods, such as potatoes have a high moisture content. Condensation trapped in the door glass should clear after a few hours.
Flashing or arcing from within the cavity when cooking.	Arcing will occur when a metallic object comes into close proximity to the oven cavity during cooking. This may possibly roughen the surface of the cavity, but would not otherwise damage the oven.
Arcing potatoes.	Ensure all "eyes" are removed from the potatoes and that they have been pierced, place directly onto the turntable or in a heat resistant flan dish or similar.
The display is lit but the control panel will not work when pressed.	Check the door is closed properly.
Oven cooks too slowly.	Ensure correct power level has been selected.
Oven makes a noise.	The microwave energy pulses ON and OFF during cooking/defrosting.
Outer cabinet is hot.	The cabinet may become warm to the touch - keep children away.

TO REPLACE THE MAINS PLUG



The wires in the mains cable are colour coded as shown:

Green and yellow stripes = **EARTH**
Blue = **NEUTRAL**
Brown = **LIVE**

As the colours in the mains lead of your oven may not correspond with the coloured marking identifying the terminals in your plug, connect the wires as described:

- The green and yellow wire to the plug terminal marked E  or coloured green or coloured green and yellow.
- The blue wire to the plug terminal marked N or coloured black or coloured blue.
- The brown wire to the plug terminal marked L or coloured red or coloured brown.

Make sure the terminal screws are tight and the cable is held securely by the cable grip where it enters the plug.

Like most appliances in your home, your oven must be connected to a single phase 220-230V, 50Hz alternating current supply.

If you do not make the proper electrical connections you might damage the oven or injure yourself. Neither SHARP nor the supplier will be liable if this happens.

WARNING: THIS APPLIANCE MUST BE EARTHED
If you have any doubts about your electrical supply ask a qualified electrician.

SHARP

บริษัท ชาร์ป ไทย จำกัด

6/10 อาคารพีพัฒนาสิน ชั้น19-20
ซอยพัฒนาสิน ถนนนราธิวาสราชนครินทร์
แขวงทุ่งมหาเมฆ เขตสาทร กรุงเทพฯ 10120

โทรศัพท์ 0 2855 8899 โทรสาร 0 2855 8500

<https://www.th.sharp>

ศูนย์ลูกค้าสัมพันธ์ 0 2855 8888